

CE EMC Test Report

Report No.: CE151201D13

Test Model: UE-1008

Series Model: Vecow UE Series, UE-1004,
UE-XXXXXXXXXX ("X" can be 0-9, A-Z or blank for marketing purpose)

Received Date: Dec. 1, 2015

Test Date: Dec. 4 ~ 10, 2015

Issued Date: Dec. 14, 2015

Applicant: Vecow Co., Ltd.

Address: 12F., No. 111, Zhongcheng Rd., Tucheng Dist., New Taipei City 23674 Taiwan
(R. O. C.)

Issued By: Bureau Veritas Consumer Products Services (H.K.) Ltd., Taoyuan Branch

Lab Address: No. 47-2, 14th Ling, Chia Pau Vil., Lin Kou Dist., New Taipei City, Taiwan (R.O.C.)



This report is for your exclusive use. Any copying or replication of this report to or for any other person or entity, or use of our name or trademark, is permitted only with our prior written permission. This report sets forth our findings solely with respect to the test samples identified herein. The results set forth in this report are not indicative or representative of the quality or characteristics of the lot from which a test sample was taken or any similar or identical product unless specifically and expressly noted. Our report includes all of the tests requested by you and the results thereof based upon the information that you provided to us. You have 60 days from date of issuance of this report to notify us of any material error or omission caused by our negligence, provided, however, that such notice shall be in writing and shall specifically address the issue you wish to raise. A failure to raise such issue within the prescribed time shall constitute your unqualified acceptance of the completeness of this report, the tests conducted and the correctness of the report contents. Unless specific mention, the uncertainty of measurement has been explicitly taken into account to declare the compliance or non-compliance to the specification. The report must not be used by the client to claim product certification, approval, or endorsement by NVLAP, NIST, or any agency of the federal government. The report must not be used by the client to claim product certification, approval, or endorsement by TAF or any government agencies.

Table of Contents

Release Control Record	4
1 Certificate of Conformity	5
2 Summary of Test Results	6
2.1 Measurement Uncertainty.....	7
2.2 Modification Record.....	7
3 General Information	8
3.1 Features of EUT.....	8
3.2 General Description of EUT	8
3.3 Operating Modes of EUT and Determination of Worst Case Operating Mode.....	8
3.4 Test Program Used and Operation Descriptions.....	8
3.5 Primary Clock Frequencies of Internal Source	8
4 Configuration and Connections with EUT	9
4.1 Connection Diagram of EUT and Peripheral Devices	9
4.2 Configuration of Peripheral Devices and Cable Connections.....	10
5 Conducted Disturbance at Mains Ports	11
5.1 Limits	11
5.2 Test Instruments.....	11
5.3 Test Arrangement.....	12
5.4 Test Results.....	13
6 Radiated Disturbance up to 1 GHz	15
6.1 Limits	15
6.2 Test Instruments.....	15
6.3 Test Arrangement.....	16
6.4 Test Results.....	17
7 Radiated Disturbance above 1 GHz	19
7.1 Limits	19
7.2 Test Instruments.....	19
7.3 Test Arrangement.....	20
7.4 Test Results.....	21
8 General Immunity Requirements	23
8.1 Performance Criteria	23
9 Electrostatic Discharge Immunity Test (ESD)	24
9.1 Test Specification.....	24
9.2 Test Instruments.....	24
9.3 Test Arrangement.....	24
9.4 Test Results.....	26
10 Radiated, Radio-frequency, Electromagnetic Field Immunity Test (RS)	27
10.1 Test Specification.....	27
10.2 Test Instruments.....	27
10.3 Test Arrangement.....	28
10.4 Test Results.....	29

11	Power Frequency Magnetic Field Immunity Test	30
11.1	Test Specification.....	30
11.2	Test Instruments	30
11.3	Test Arrangement	30
11.4	Test Results.....	31
12	Pictures of Test Arrangements.....	32
12.1	Conducted Disturbance at Mains Ports	32
12.2	Radiated Disturbance up to 1 GHz	33
12.3	Radiated Disturbance above 1 GHz.....	34
12.4	Electrostatic Discharge Immunity Test (ESD)	35
12.5	Radio-frequency, Electromagnetic Field Immunity Test (RS)	36
12.6	Power Frequency Magnetic Field Immunity Test (PFMF).....	37
	Appendix – Information on the Testing Laboratories.....	38



Release Control Record

Issue No.	Description	Date Issued
CE151201D13	Original release.	Dec. 14, 2015

1 Certificate of Conformity

Product: PCI Express x4, 8 Ports/ 4 Ports USB 3.0 Expansion Card
Brand: Vecow
Test Model: UE-1008
Series Model: Vecow UE Series, UE-1004,
UE-XXXXXXXXXX ("X" can be 0-9, A-Z or blank for marketing purpose)
Sample Status: Engineering sample
Applicant: Vecow Co., Ltd.
Test Date: Dec. 4 ~ 10, 2015
Standards: **EN 55022:2010 +AC:2011, Class B**
CISPR 22:2008, Class B
AS/NZS CISPR 22:2009 +A1:2010, Class B
EN 61000-3-2:2014 (Not Applicable)
EN 61000-3-3:2013 (Not Applicable)
EN 55024:2010
EN 61000-4-2:2009 / IEC 61000-4-2:2008 ED. 2.0
EN 61000-4-3:2006 +A1:2008 +A2:2010 / IEC 61000-4-3:2010 ED. 3.2
EN 61000-4-4:2012 / IEC 61000-4-4:2012 ED. 3.0 (Not Applicable)
EN 61000-4-5:2006 / IEC 61000-4-5:2005 ED. 2.0 (Not Applicable)
EN 61000-4-6:2014 / IEC 61000-4-6:2013 ED. 4.0 (Not Applicable)
EN 61000-4-8:2010 / IEC 61000-4-8:2009 ED. 2.0
EN 61000-4-11:2004 / IEC 61000-4-11:2004 ED. 2.0 (Not Applicable)

The above equipment has been tested by **Bureau Veritas Consumer Products Services (H.K.) Ltd., Taoyuan Branch**, and found compliance with the requirement of the above standards. The test record, data evaluation & Equipment Under Test (EUT) configurations represented herein are true and accurate accounts of the measurements of the sample's EMC characteristics under the conditions specified in this report.

Prepared by :



, Date: Dec. 14, 2015

Sandra Lin / Specialist

Approved by :



, Date: Dec. 14, 2015

Henry Lai / Director

2 Summary of Test Results

Emission				
Standard	Clause	Test Item	Result/Remarks	Verdict
EN 55022:2010 +AC:2011 CISPR 22:2008 AS/NZS CISPR 22:2009 +A1:2010	5.1	Mains terminal disturbance voltage	Minimum passing Class B margin is -6.82 dB at 0.19297 MHz	Pass
	5.2	Conducted common mode (asymmetric mode) disturbance at telecommunication ports	Without telecom port of the EUT	N/A
	6.1	Radiated disturbance 30-1000 MHz	Minimum passing Class B margin is -3.39 dB at 145.20 MHz	Pass
	6.2	Radiated disturbance above 1GHz	Minimum passing Class B margin is -5.24 dB at 1999.23 MHz	Pass
EN 61000-3-2:2014	-	Harmonic current emissions	Test not applicable because port does not exist	N/A
EN 61000-3-3:2013	-	Voltage fluctuations and flicker	Test not applicable because port does not exist	N/A

Immunity				
EN 55024 Clause	Basic standard	Test Item	Result/Remarks	Verdict
4.2.1	EN 61000-4-2:2009 / IEC 61000-4-2:2008 ED. 2.0	Electrostatic discharges (ESD)	Performance Criterion B	Pass
4.2.3.2	EN 61000-4-3:2006 +A1:2008 +A2:2010 / IEC 61000-4-3:2010 ED. 3.2	Continuous radiated disturbances (RS)	Performance Criterion A	Pass
4.2.2	EN 61000-4-4:2012 / IEC 61000-4-4:2012 ED. 3.0	Electrical fast transients (EFT)	EUT's cable length is not greater than 3m and EUT consumes DC power	N/A
4.2.5	EN 61000-4-5:2006 / IEC 61000-4-5:2005 ED. 2.0	Surges	EUT doesn't connect directly to outdoor cables and EUT consumes DC power	N/A
4.2.3.3	EN 61000-4-6:2014/ IEC 61000-4-6:2013 ED. 4.0	Continuous conducted disturbances (CS)	EUT's cable length is not greater than 3m and EUT consumes DC power	N/A
4.2.4	EN 61000-4-8:2010 / IEC 61000-4-8:2009 ED. 2.0	Power-frequency magnetic fields (PFMF)	Performance Criterion A	Pass
4.2.6	EN 61000-4-11:2004 / IEC 61000-4-11:2004 ED. 2.0	Voltage dips and interruptions	Test not applicable because AC power port does not exist.	N/A

Note:

1. There is no deviation to the applied test methods and requirements covered by the scope of this report.
2. The above EN/IEC basic standards are applied with latest version if customer has no special requirement.
3. N/A: Not Applicable

2.1 Measurement Uncertainty

Where relevant, the following measurement uncertainty levels have been estimated for tests performed on the EUT as specified in CISPR 16-4-2:

The listed uncertainties are the worst case uncertainty for the entire range of measurement. Please note that the uncertainty values are provided for informational purposes only and are not used in determining the PASS/FAIL results.

Measurement	Expanded Uncertainty (k=2) (\pm)	Maximum allowable uncertainty (\pm)
Conducted disturbance at mains port using AMN, 150kHz ~ 30MHz	2.78 dB	3.4 dB (U_{cispr})
Radiated disturbance, 30MHz ~ 1GHz	3.73 dB	6.3 dB (U_{cispr})
Radiated disturbance, 1GHz ~ 6GHz	3.36 dB	5.2 dB (U_{cispr})

2.2 Modification Record

There were no modifications required for compliance.

3 General Information

3.1 Features of EUT

The tests reported herein were performed according to the method specified by Vecow Co., Ltd., for detailed feature description, please refer to the manufacturer's specifications or user's manual.

3.2 General Description of EUT

Product	PCI Express x4, 8 Ports/ 4 Ports USB 3.0 Expansion Card
Brand	Vecow
Test Model	UE-1008
Series Model	Vecow UE Series, UE-1004, UE-XXXXXXXXXX ("X" can be 0-9, A-Z or blank for marketing purpose)
Model Difference	Marketing Differentiation
Sample Status	Engineering sample
Operating Software	N/A
Power Supply Rating	DC 5.0V from PC

Note:

The EUT is a PCI Express x4, 8 Ports/ 4 Ports USB 3.0 Expansion Card with 4 independent USB controllers and up to 8 USB ports interface (including USB 3.0 & USB 2.0).

3.3 Operating Modes of EUT and Determination of Worst Case Operating Mode

The EUT is consumes power from PC, which designed with AC power supply of rating 100-240Vac, 50-60Hz. For radiated emission evaluation, 230Vac/50Hz (for EN 55022), 120Vac/60Hz (for FCC Part 15) had been covered during the pre-test. The worst radiated emission data was founded at **230Vac/50Hz** and recorded in the applied test report.

The EUT were pre-tested with USB 3.0 & USB 2.0 modes, the worst emission level was found on USB 3.0 mode. Therefore this mode was applied for final test and only its test data was recorded in this report.

3.4 Test Program Used and Operation Descriptions

◆ For Conducted & Radiated test:

- a. Installed PCI Express x4, 8 Ports/ 4 Ports USB 3.0 Expansion Card (EUT) into PC.
- b. Turned on the power of all equipment.
- c. PC ran a test program to enable all functions.
- d. PC read and wrote messages from/to HDD & ext. USB HDDs via EUT.
- e. PC sent "H" messages to monitor and it displayed "H" patterns on its screen.
- f. PC sent messages to printer, and then printer printed out.
- g. PC sent messages to modem.
- h. Repeated steps c-g.

◆ For Harmonics, Flicker, Immunity tests:

- a. Installed PCI Express USB3.0 4 port Express card (EUT) into PC.
- b. Turned on the power of all equipment.
- c. PC ran WinEMC test program to enable all functions.
- d. PC read and wrote messages from/to ext. USB HDDs via EUT.
- e. PC sent "H" messages to monitor and it displayed "H" patterns on its screen.
- f. Repeated steps c-e.

3.5 Primary Clock Frequencies of Internal Source

The highest frequency generated or used within the EUT or on which the EUT operates or tunes is 5Gbps, provided by Vecow Co., Ltd., for detailed internal source, please refer to the manufacturer's specifications.

4 Configuration and Connections with EUT

4.1 Connection Diagram of EUT and Peripheral Devices

Emission tests (Harmonics & Flicker excluded):

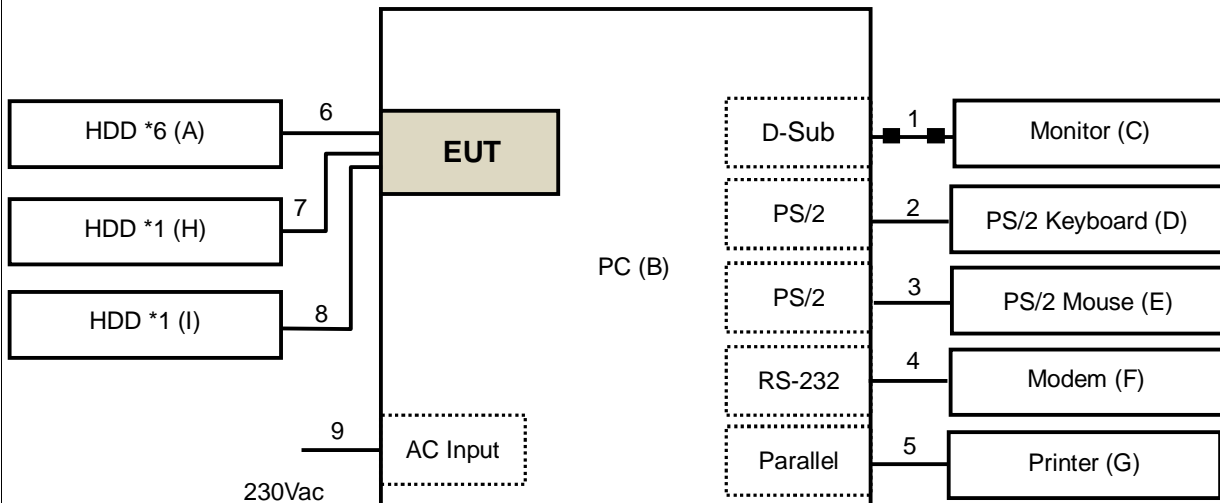

Harmonics, Flicker, Immunity tests:

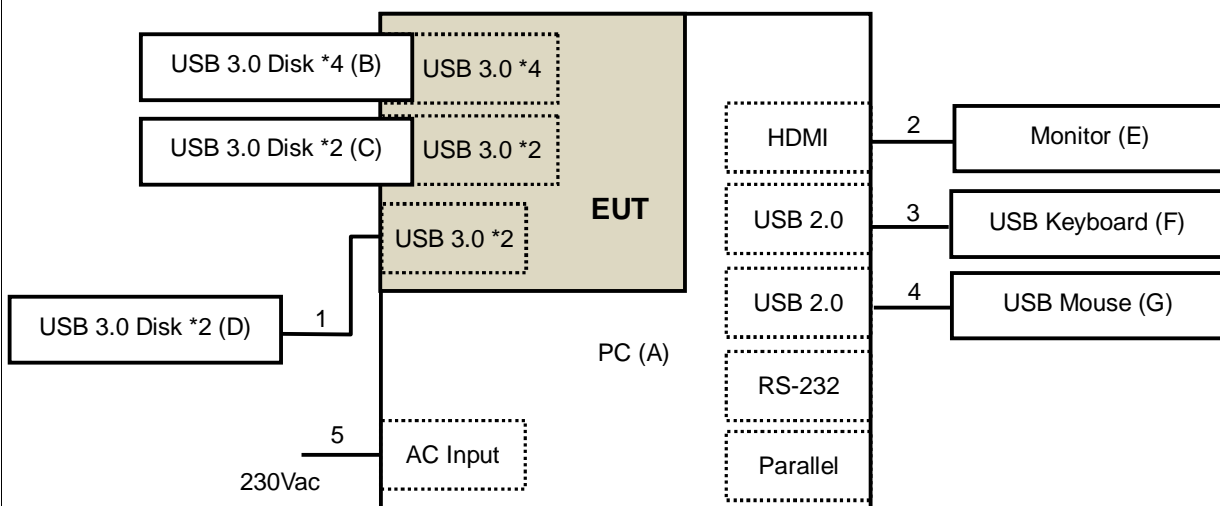

4.2 Configuration of Peripheral Devices and Cable Connections

Emission tests (Harmonics & Flicker excluded):

ID	Product	Brand	Model No.	Serial No.	FCC ID	Remarks
A.	USB 3.0 Hard Disk	WD	WDBACY5000ABL-PESN	WX11E91JE773	FCC DoC Approved	Provided by Lab
	USB 3.0 Hard Disk	WD	WDBACY5000ABL-PESN	WXG1A91A9208	FCC DoC Approved	Provided by Lab
	USB 3.0 Hard Disk	WD	WDBACY5000ABL-PESN	WX71E91FXHL1	FCC DoC Approved	Provided by Lab
	USB 3.0 Hard Disk	WD	WDBACY5000ABL-PESN	WX61A9115393	FCC DoC Approved	Provided by Lab
	USB 3.0 Hard Disk	WD	WDBACY5000ABL-PESN	WXA1A81U3670	FCC DoC Approved	Provided by Lab
	USB 3.0 Hard Disk	WD	WDBACY5000ABL-PESN	WXH1A91A6872	FCC DoC Approved	Provided by Lab
B.	PC	HP	DX-7400MT	SGH8460H2S	FCC DoC Approved	Provided by Lab
C.	24" LCD Monitor	DELL	U2410	CN082W/XD728720CC0 KDL	FCC DoC Approved	Provided by Lab
D.	PS/2 Keyboard	HP	KB-0316	BC3520GVBWT0XZ	FCC DoC Approved	Provided by Lab
E.	PS/2 Mouse	BTC	M851	N/A	E5XMSM860	Provided by Lab
F.	Modem	ACEEX	1414	980020506	IFAXDM1414	Provided by Lab
G.	Printer	EPSON	LQ-300+II	G88Y058151	FCC DoC Approved	Provided by Lab
H.	USB 3.0 Hard Disk	WD	WDBACY5000ABL-PESN	WXD1E91KNHR8	FCC DoC Approved	Provided by Lab
I.	External Hard Disk	Seagate	SRD00F2	NA4M1SB3	FCC DoC Approved	Provided by Lab

Note: All power cords of the above support units are non-shielded (1.8m).

ID	Descriptions	Qty.	Length (m)	Shielding (Yes/No)	Cores (Qty.)	Remarks
1.	D-SUB cable	1	1.8	Y	2	Provided by Lab
2.	PS/2 cable	1	1.5	Y	0	Provided by Lab
3.	PS/2 cable	1	1.2	Y	0	Provided by Lab
4.	RS-232 cable	1	1.8	Y	0	Provided by Lab
5.	Parallel cable	1	1.8	Y	0	Provided by Lab
6.	USB cable	6	0.4	Y	0	Provided by Lab
7.	USB cable	1	1.2	Y	0	Provided by Lab
8.	USB cable	1	1.2	Y	0	Provided by Lab
9.	AC power cable	1	1.8	N	0	Provided by Lab

Note: The core(s) is(are) originally attached to the cable(s).

Harmonics, Flicker, Immunity tests:

ID	Product	Brand	Model No.	Serial No.	FCC ID	Remarks
A.	Personal Computer	DELL	VOSTRO 470	4VBJYBX	FCC DOC Approved	Provided by Lab
B.	USB 3.0 Hard Disk *4	HP	X750W	N/A	FCC DoC Approved	Provided by Lab
C.	USB 3.0 Hard Disk *2	Verbatim	Type-C OTG Drive	N/A	FCC DoC Approved	Provided by Lab
D.	USB 3.0 Hard Disk	BUFFALO	HD-HX1	45564801200012	FCC DoC Approved	Provided by Lab
	USB 2.0 Hard Disk	BUFFALO	HD-LBU2	55519210504241	FCC DoC Approved	Provided by Lab
E.	24" LCD MONITOR	DELL	U2413f	CN-06VNX5-72872- 46D-A89L	FCC DoC Approved	Provided by Lab
F.	USB Keyboard	HP	SK-2085	N/A	FCC DoC Approved	Provided by Lab
G.	USB Mouse	HP	M-U0031-O	N/A	FCC DoC Approved	Provided by Lab

Note: All power cords of the above support units are non-shielded (1.8m).

ID	Descriptions	Qty.	Length (m)	Shielding (Yes/No)	Cores (Qty.)	Remarks
1.	USB 3.0 cable	1	1.0	Y	0	Provided by Lab
2.	HDMI cable	1	1.8	Y	0	Provided by Lab
3.	USB cable	1	1.8	Y	0	Provided by Lab
4.	USB cable	1	1.8	Y	0	Provided by Lab
5.	AC power cable	1	1.8	N	0	Provided by Lab

Note: The core(s) is(are) originally attached to the cable(s).

5 Conducted Disturbance at Mains Ports

5.1 Limits

Frequency (MHz)	Class A (dBuV)		Class B (dBuV)	
	Quasi-peak	Average	Quasi-peak	Average
0.15 - 0.5	79	66	66 - 56	56 - 46
0.50 - 5.0	73	60	56	46
5.0 - 30.0	73	60	60	50

Notes: 1. The lower limit shall apply at the transition frequencies.
 2. The limit decreases linearly with the logarithm of the frequency in the range of 0.15 to 0.50 MHz.

5.2 Test Instruments

Description & Manufacturer	Model No.	Serial No.	Cal. Date	Cal. Due
ROHDE & SCHWARZ TEST RECEIVER	ESCS 30	100290	Dec. 27, 2014	Dec. 26, 2015
ROHDE & SCHWARZ Artificial Mains Network (for EUT)	ENV 216	101196	Apr. 17, 2015	Apr. 16, 2016
LISN With Adapter (for EUT)	AD10	C09Ada-001	Apr. 17, 2015	Apr. 16, 2016
ROHDE & SCHWARZ Artificial Mains Network (for peripherals)	ESH3-Z5	847265/023	Oct. 21, 2015	Oct. 20, 2016
SCHWARZBECK Artificial Mains Network (For EUT)	NNLK8129	8129229	May 06, 2015	May 05, 2016
Software	Cond_V7.3.7	NA	NA	NA
RF cable (JYEBAO) With 10dB PAD	5D-FB	Cable-C09.01	Feb. 24, 2015	Feb. 23, 2016
SUHNER Terminator (For ROHDE & SCHWARZ LISN)	65BNC-5001	E1-010789	May 19, 2015	May 18, 2016
ROHDE & SCHWARZ Artificial Mains Network (For TV EUT)	ESH3-Z5	100220	Nov. 13, 2015	Nov. 12, 2016
LISN With Adapter (for TV EUT)	100220	N/A	Nov. 13, 2015	Nov. 12, 2016

Notes: 1. The calibration interval of the above test instruments is 12 months and the calibrations are traceable to NML/ROC and NIST/USA.
 2. The test was performed in Shielded Room No. 9.
 3. The VCCI Site Registration No. C-1312.
 4. Tested Date: Dec. 4, 2015.

5.3 Test Arrangement

- The EUT was placed 0.4 meters from the conducting wall of the shielded room with EUT being connected to the power mains through a line impedance stabilization network (LISN). Other support units were connected to the power mains through another LISN. The two LISNs provide 50 Ohm/ 50uH of coupling impedance for the measuring instrument.
- Both lines of the power mains connected to the EUT were checked for maximum conducted interference.
- The test results of conducted emissions at mains ports are recorded of six worst margins for quasi-peak (mandatory) [and average (if necessary)] values against the limits at frequencies of interest unless the margin is 20 dB or greater.

Note: The resolution bandwidth and video bandwidth of test receiver is 9kHz for quasi-peak detection (QP) and average detection (AV) at frequency 0.15MHz-30MHz.

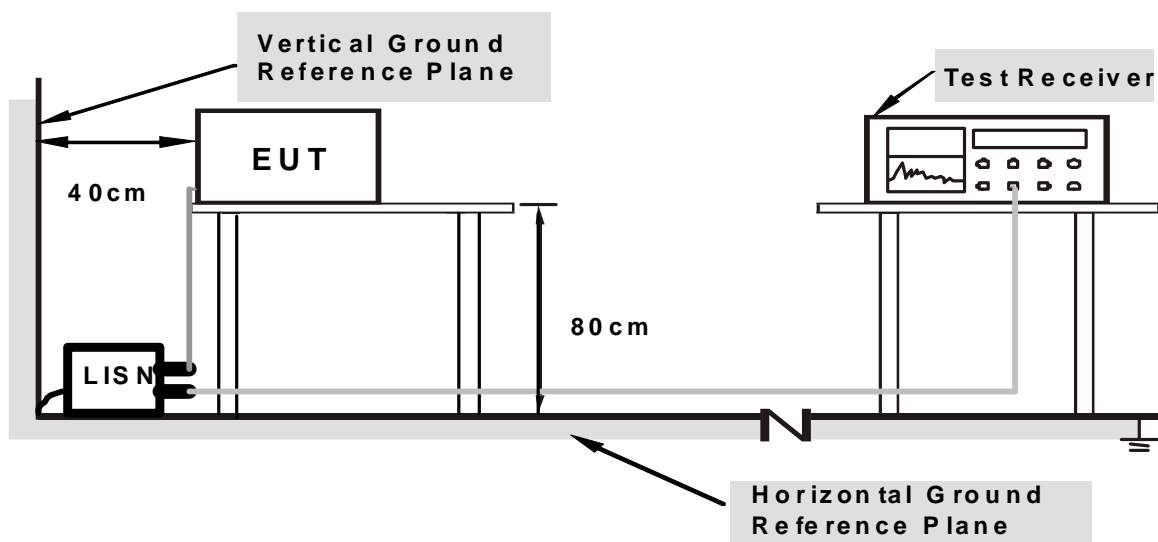

Note: Support units were connected to second LISN.

For the actual test configuration, please refer to the related item – Photographs of the Test Configuration.

5.4 Test Results

Frequency Range	150kHz ~ 30MHz	Detector Function & Bandwidth	Quasi-Peak (QP) / Average (AV), 9kHz
Input Power <From system>	230Vac, 50Hz	Environmental Conditions	18°C, 75%RH
Tested by	Vincent Lin		
Test Mode	With system		

Phase Of Power : Line (L)										
No	Frequency (MHz)	Correction Factor (dB)	Reading Value (dBuV)		Emission Level (dBuV)		Limit (dBuV)		Margin (dB)	
			Q.P.	AV.	Q.P.	AV.	Q.P.	AV.	Q.P.	AV.
1	0.19304	9.71	41.50	37.01	51.21	46.72	63.90	53.90	-12.70	-7.19
2	0.25810	9.72	27.34	25.43	37.06	35.15	61.49	51.49	-24.43	-16.34
3	0.50284	9.76	22.85	18.30	32.61	28.06	56.00	46.00	-23.39	-17.94
4	2.32813	9.87	24.23	19.37	34.10	29.24	56.00	46.00	-21.90	-16.76
5	11.08203	10.00	21.96	16.78	31.96	26.78	60.00	50.00	-28.04	-23.22
6	23.96222	10.06	33.31	23.43	43.37	33.49	60.00	50.00	-16.63	-16.51

Remarks:

1. Q.P. and AV. are abbreviations of quasi-peak and average individually.
2. The emission levels of other frequencies were very low against the limit.
3. Margin value = Emission level – Limit value
4. Correction factor = Insertion loss + Cable loss
5. Emission Level = Correction Factor + Reading Value

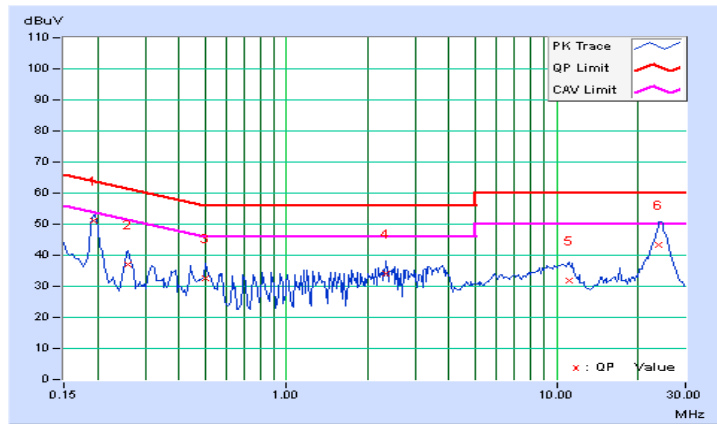

Frequency Range	150kHz ~ 30MHz	Detector Function & Bandwidth	Quasi-Peak (QP) / Average (AV), 9kHz
Input Power <From system>	230Vac, 50Hz	Environmental Conditions	18°C, 75%RH
Tested by	Vincent Lin		
Test Mode	With system		

Phase Of Power : Neutral (N)										
No	Frequency (MHz)	Correction Factor (dB)	Reading Value (dBuV)		Emission Level (dBuV)		Limit (dBuV)		Margin (dB)	
			Q.P.	AV.	Q.P.	AV.	Q.P.	AV.	Q.P.	AV.
1	0.19297	9.68	40.25	37.41	49.93	47.09	63.91	53.91	-13.98	-6.82
2	0.25676	9.69	27.34	24.16	37.03	33.85	61.54	51.54	-24.51	-17.69
3	0.50419	9.72	22.14	18.08	31.86	27.80	56.00	46.00	-24.14	-18.20
4	2.13808	9.82	23.15	18.57	32.97	28.39	56.00	46.00	-23.03	-17.61
5	10.93359	9.96	21.80	16.70	31.76	26.66	60.00	50.00	-28.24	-23.34
6	24.15234	10.09	31.68	22.34	41.77	32.43	60.00	50.00	-18.23	-17.57

Remarks:

1. Q.P. and AV. are abbreviations of quasi-peak and average individually.
2. The emission levels of other frequencies were very low against the limit.
3. Margin value = Emission level – Limit value
4. Correction factor = Insertion loss + Cable loss
5. Emission Level = Correction Factor + Reading Value

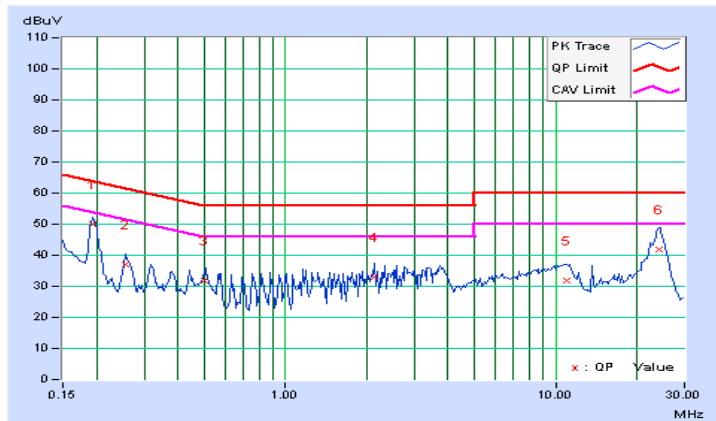

6 Radiated Disturbance up to 1 GHz

6.1 Limits

Frequency (MHz)	Class A (at 10m)	Class B (at 10m)
	dBuV/m	dBuV/m
30 - 230	40	30
230 - 1000	47	37

- Notes: 1. The lower limit shall apply at the transition frequencies.
 2. Emission level (dBuV/m) = 20 log Emission level (uV/m).
 3. All emanations from a class A/B digital device or system, including any network of conductors and apparatus connected thereto, shall not exceed the level of field strengths specified above.

6.2 Test Instruments

Description & Manufacturer	Model No.	Serial No.	Cal. Date	Cal. Due
ROHDE & SCHWARZ TEST RECEIVER	ESCI	100744	Apr. 24, 2015	Apr. 23, 2016
Schaffner BILOG Antenna	CBL6111D	22270	Feb. 03, 2015	Feb. 02, 2016
CT Turn Table	TT100	CT-080	NA	NA
CT Tower	AT100	CT-080	NA	NA
Software	Radiated_V7.6.15.9.4	NA	NA	NA
ANRITSU RF Switches	MP59B	N/A	Nov. 20, 2015	Nov. 19, 2016
WOKEN RF cable	8D	CABLE-ST3-01	Nov. 20, 2015	Nov. 19, 2016

- Notes: 1. The calibration interval of the above test instruments is 12 months and the calibrations are traceable to NML/ROC and NIST/USA.
 2. The test was performed in Open Site No. 3.
 3. The VCCI Site Registration No. is R-269.
 4. The FCC Site Registration No. 90424.
 5. Tested Date: Dec. 4, 2015.

6.3 Test Arrangement

- The EUT was placed on the top of a rotating table 0.8 meters above the ground at an accredited test facility. The table was rotated 360 degrees to determine the position of the highest radiation.
- The EUT was set 10 meters away from the interference-receiving antenna, which was mounted on the top of a variable-height antenna tower.
- The antenna is a broadband antenna, and its height is varied from one meter to four meters above the ground to determine the maximum value of the field strength. Both horizontal and vertical polarizations of the antenna are set to make the measurement.
- For each suspected emission, the EUT was arranged to its worst case and then the antenna was tuned to heights from 1 meter to 4 meters and the rotatable table was turned from 0 degrees to 360 degrees to find the maximum reading.
- The test-receiver system was set to quasi-peak detect function and specified bandwidth with maximum hold mode when the test frequency is up to 1 GHz.

Note: The resolution bandwidth and video bandwidth of test receiver/spectrum analyzer is 120kHz for quasi-peak detection (QP) at frequency up to 1GHz.

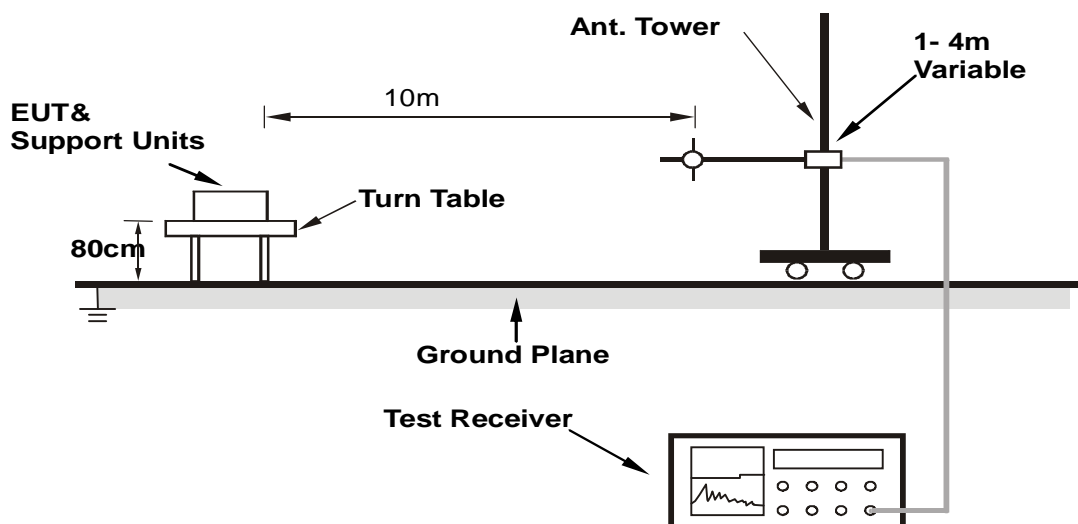

For the actual test configuration, please refer to the related item – Photographs of the Test Configuration.

6.4 Test Results

Frequency Range	30MHz ~ 1GHz	Detector Function & Bandwidth	Quasi-Peak (QP), 120kHz
Tested by	Chin Wen Wang	Environmental Conditions	20°C, 64%RH
Test Mode	With system		

Antenna Polarity & Test Distance : Horizontal at 10 m

No	Frequency (MHz)	Emission Level (dBuV/m)	Limit (dBuV/m)	Margin (dB)	Antenna Height (m)	Table Angle (Degree)	Raw Value (dBuV)	Correction Factor (dB/m)
1	78.40	21.26 QP	30.00	-8.74	4.00 H	277	12.90	8.36
2	126.75	22.33 QP	30.00	-7.67	4.00 H	134	8.88	13.45
3	178.40	26.28 QP	30.00	-3.72	4.00 H	1	14.96	11.32
4	200.05	26.20 QP	30.00	-3.80	4.00 H	2	14.77	11.43
5	218.15	25.01 QP	30.00	-4.99	4.00 H	249	13.18	11.83
6	280.90	33.28 QP	37.00	-3.72	2.82 H	241	17.62	15.66
7	532.75	30.38 QP	37.00	-6.62	1.66 H	330	8.27	22.11
8	750.25	31.17 QP	37.00	-5.83	1.32 H	329	4.74	26.43
9	810.25	29.77 QP	37.00	-7.23	1.18 H	16	3.25	26.52

Remarks:

1. Emission Level(dBuV/m) = Raw Value(dBuV) + Correction Factor(dB/m)
2. Correction Factor(dB/m) = Antenna Factor (dB/m) + Cable Factor (dB) – Pre-Amplifier Factor (dB)
3. The other emission levels were very low against the limit.
4. Margin value = Emission level – Limit value

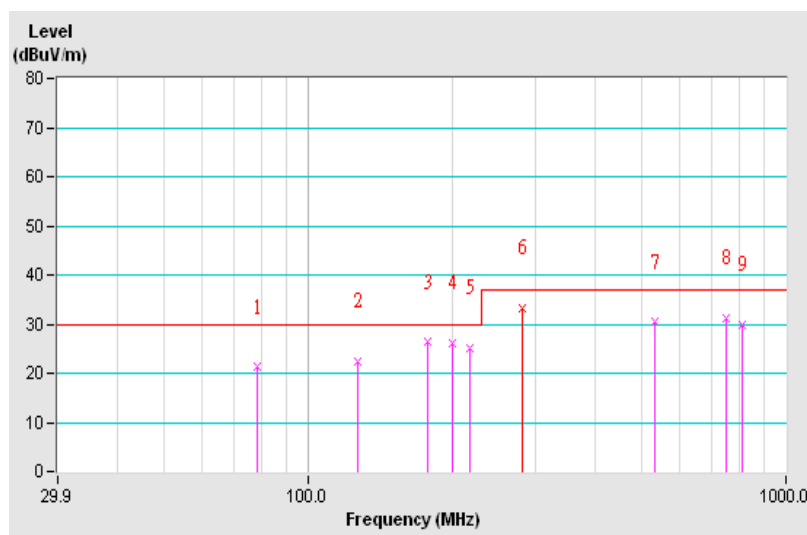

Frequency Range	30MHz ~ 1GHz	Detector Function & Bandwidth	Quasi-Peak (QP), 120kHz
Tested by	Chin Wen Wang	Environmental Conditions	20°C, 64%RH
Test Mode	With system		

Antenna Polarity & Test Distance : Vertical at 10 m								
No	Frequency (MHz)	Emission Level (dBuV/m)	Limit (dBuV/m)	Margin (dB)	Antenna Height (m)	Table Angle (Degree)	Raw Value (dBuV)	Correction Factor (dB/m)
1	59.40	24.02 QP	30.00	-5.98	1.23 V	75	16.78	7.24
2	85.45	23.59 QP	30.00	-6.41	1.65 V	270	14.05	9.54
3	114.10	22.80 QP	30.00	-7.20	1.00 V	236	9.53	13.27
4	145.20	26.61 QP	30.00	-3.39	1.00 V	78	13.23	13.38
5	155.95	22.17 QP	30.00	-7.83	1.00 V	258	9.19	12.98
6	200.05	22.41 QP	30.00	-7.59	1.00 V	121	10.98	11.43
7	281.00	31.61 QP	37.00	-5.39	1.00 V	230	15.95	15.66
8	652.00	29.15 QP	37.00	-7.85	2.03 V	160	4.72	24.43
9	750.25	28.55 QP	37.00	-8.45	1.72 V	285	2.12	26.43
10	987.25	31.04 QP	37.00	-5.96	2.86 V	196	1.37	29.67

Remarks:

1. Emission Level(dBuV/m) = Raw Value(dBuV) + Correction Factor(dB/m)
2. Correction Factor(dB/m) = Antenna Factor (dB/m) + Cable Factor (dB) – Pre-Amplifier Factor (dB)
3. The other emission levels were very low against the limit.
4. Margin value = Emission level – Limit value

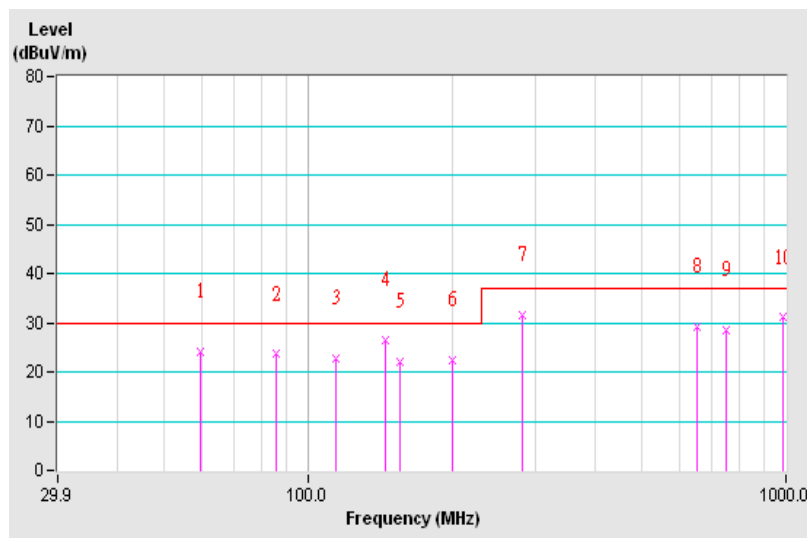

7 Radiated Disturbance above 1 GHz

7.1 Limits

Frequency (GHz)	Class A (dBuV/m) (at 3m)		Class B (dBuV/m) (at 3m)	
	Average	Peak	Average	Peak
1 to 3	56	76	50	70
3 to 6	60	80	54	74

- Notes: 1. The lower limit shall apply at the transition frequencies.
 2. Emission level (dBuV/m) = 20 log Emission level (uV/m).
 3. All emanations from a class A/B digital device or system, including any network of conductors and apparatus connected thereto, shall not exceed the level of field strengths specified above.

Frequency Range (For unintentional radiators)

Highest frequency generated or used in the EUT or on which the EUT operates or tunes (MHz)	Upper frequency of measurement range (MHz)
Below 108	1000
108-500	2000
500-1000	5000
Above 1000	Up to 5 times of the highest frequency or 6 GHz, whichever is less

7.2 Test Instruments

Description & Manufacturer	Model No.	Serial No.	Cal. Date	Cal. Due
Agilent Spectrum	E4446A	MY51100009	May 30, 2015	May 29, 2016
Agilent Test Receiver	N9038A	MY51210137	Jul. 13, 2015	Jul. 12, 2016
Agilent Preamplifier	8449B	3008A01292	Feb. 26, 2015	Feb. 25, 2016
MITEQ Preamplifier	AMF-6F-260400-33-8P	892164	Mar. 01, 2015	Feb. 28, 2016
EMCI Preamplifier	EMC184045B	980235	Mar. 01, 2015	Feb. 28, 2016
Schwarzbeck Horn Antenna	BBHA-9170	212	Feb. 09, 2015	Feb. 08, 2016
EMCO Horn Antenna	3115	6714	Feb. 06, 2015	Feb. 05, 2016
Max Full. Turn Table	MF7802	MF780208216	NA	NA
Software	Radiated_V8.7.07	NA	NA	NA
SUHNER RF cable With 4dB PAD	SF106-18	Cable-CH10	Aug. 15, 2015	Aug. 14, 2016
SUHNER RF cable With 3dB PAD	SF102	Cable-CH8-3.6m	Aug. 15, 2015	Aug. 14, 2016

- Notes: 1. The calibration interval of the above test instruments is 12 months and the calibrations are traceable to NML/ROC and NIST/USA.
 2. The 3dB beamwidth of the horn antenna is minimum 30 degree (or $w = 1.6m$ at 3m distance) for 1~6 GHz.
 3. The test was performed in Chamber No. 10.
 4. The Industry Canada Reference No. IC 7450E-11.
 5. The VCCI Site Registration No. G-427
 6. The FCC Site Registration No. 367016
 7. Tested Date: Dec. 5, 2015.

7.3 Test Arrangement

- The EUT was placed on the top of a rotating table 0.8 meters above the ground at an accredited chamber room. The table was rotated 360 degrees to determine the position of the highest radiation.
- The EUT was set 3 meters away from the interference-receiving antenna, which was mounted on the top of a variable-height antenna tower.
- The height of antenna can be varied from one meter to four meters, the height of adjustment depends on the EUT height and the antenna 3dB beamwidth both, to detect the maximum value of the field strength. Both horizontal and vertical polarizations of the antenna are set to make the measurement.
- For each suspected emission, the EUT was arranged to its worst case and then the antenna was tuned to heights and the rotatable table was turned from 0 degrees to 360 degrees to find the maximum reading.
- The spectrum analyzer system was set to peak and average detect function and specified bandwidth with maximum hold mode when the test frequency is above 1 GHz.

Note: The resolution bandwidth of test receiver/spectrum analyzer is 1MHz and video bandwidth is 3MHz for Peak detection (PK) at frequency above 1GHz. The resolution bandwidth of test receiver/spectrum analyzer is 1 MHz for Average detection (AV) at frequency above 1GHz.

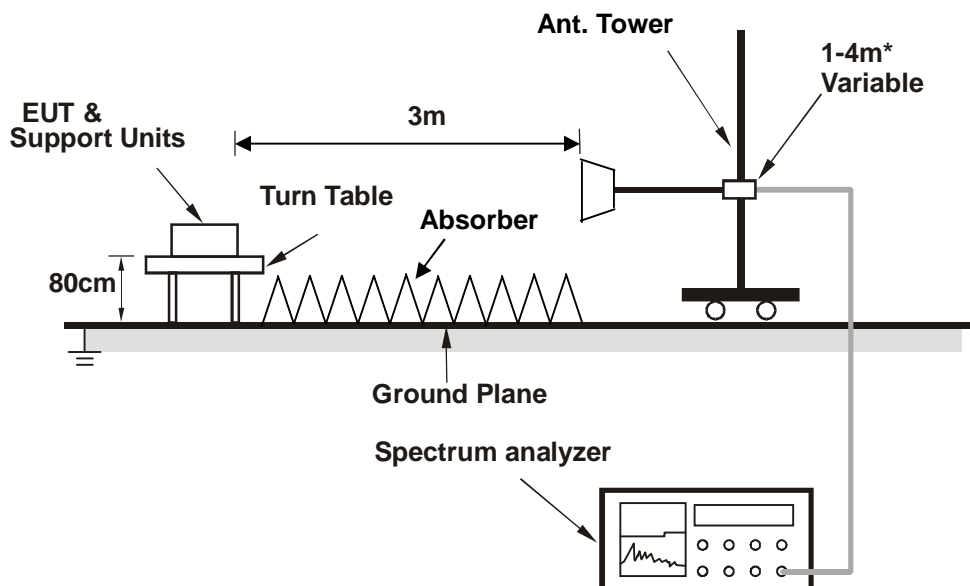

* :depends on the EUT height and the antenna 3dB beamwidth both.

For the actual test configuration, please refer to the related item – Photographs of the Test Configuration.

7.4 Test Results

Frequency Range	1GHz ~ 6GHz	Detector Function & Bandwidth	Peak (PK) / Average (AV), 1MHz
Tested by	Vincent Lin	Environmental Conditions	18°C, 75%RH
Test Mode	With system		

Antenna Polarity & Test Distance : Horizontal at 3 m								
No	Frequency (MHz)	Emission Level (dBuV/m)	Limit (dBuV/m)	Margin (dB)	Antenna Height (m)	Table Angle (Degree)	Raw Value (dBuV)	Correction Factor (dB/m)
1	1380.62	56.59 PK	70.00	-13.41	1.80 H	186	61.20	-4.61
2	1380.62	36.19 AV	50.00	-13.81	1.80 H	186	40.80	-4.61
3	1999.23	64.76 PK	70.00	-5.24	1.50 H	177	66.85	-2.09
4	1999.23	35.30 AV	50.00	-14.70	1.50 H	177	37.39	-2.09
5	2999.99	61.56 PK	70.00	-8.44	1.33 H	328	60.12	1.44
6	2999.99	35.71 AV	50.00	-14.29	1.33 H	328	34.27	1.44
7	4977.70	54.08 PK	74.00	-19.92	2.21 H	328	48.52	5.56
8	4977.70	35.48 AV	54.00	-18.52	2.21 H	328	29.92	5.56
9	5999.99	49.93 PK	74.00	-24.07	2.06 H	265	43.03	6.90
10	5999.99	37.58 AV	54.00	-16.42	2.06 H	265	30.68	6.90

Remarks:

1. Emission Level(dBuV/m) = Raw Value(dBuV) + Correction Factor(dB/m)
2. Correction Factor(dB/m) = Antenna Factor (dB/m) + Cable Factor (dB) – Pre-Amplifier Factor (dB)
3. The other emission levels were very low against the limit.
4. Margin value = Emission level – Limit value

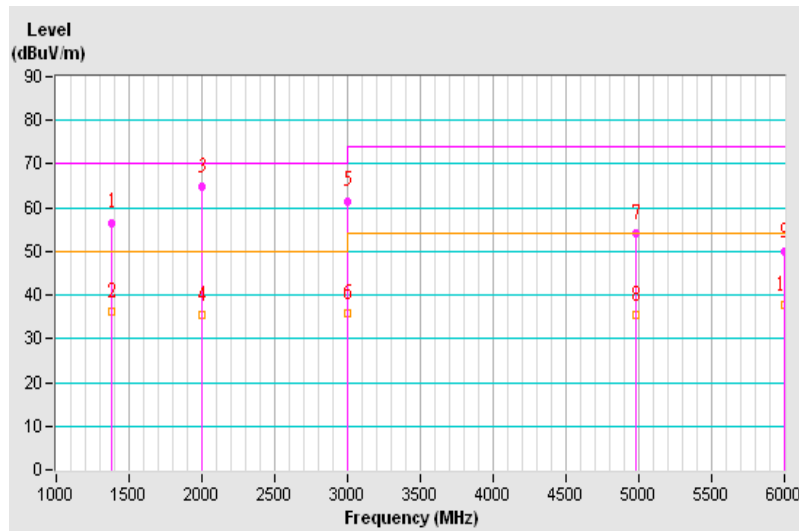

Frequency Range	1GHz ~ 6GHz	Detector Function & Bandwidth	Peak (PK) / Average (AV), 1MHz
Tested by	Vincent Lin	Environmental Conditions	18°C, 75%RH
Test Mode	With system		

Antenna Polarity & Test Distance : Vertical at 3 m								
No	Frequency (MHz)	Emission Level (dBuV/m)	Limit (dBuV/m)	Margin (dB)	Antenna Height (m)	Table Angle (Degree)	Raw Value (dBuV)	Correction Factor (dB/m)
1	1376.02	56.24 PK	70.00	-13.76	2.10 V	147	60.87	-4.63
2	1376.02	32.77 AV	50.00	-17.23	2.10 V	147	37.40	-4.63
3	1521.61	55.43 PK	70.00	-14.57	1.39 V	217	59.64	-4.21
4	1521.61	31.43 AV	50.00	-18.57	1.39 V	217	35.64	-4.21
5	1999.95	52.99 PK	70.00	-17.01	1.25 V	1	55.08	-2.09
6	1999.95	42.21 AV	50.00	-7.79	1.25 V	1	44.30	-2.09
7	2099.86	55.71 PK	70.00	-14.29	1.00 V	29	57.65	-1.94
8	2099.86	35.24 AV	50.00	-14.76	1.00 V	29	37.18	-1.94
9	2249.95	53.52 PK	70.00	-16.48	2.14 V	158	54.86	-1.34
10	2249.95	37.05 AV	50.00	-12.95	2.14 V	158	38.39	-1.34
11	2999.20	57.31 PK	70.00	-12.69	1.31 V	48	55.87	1.44
12	2999.20	34.37 AV	50.00	-15.63	1.31 V	48	32.93	1.44
13	4981.31	52.20 PK	74.00	-21.80	1.32 V	110	46.64	5.56
14	4981.31	35.30 AV	54.00	-18.70	1.32 V	110	29.74	5.56
15	5999.97	50.35 PK	74.00	-23.65	2.20 V	346	43.45	6.90
16	5999.97	37.36 AV	54.00	-16.64	2.20 V	346	30.46	6.90

Remarks:

1. Emission Level(dBuV/m) = Raw Value(dBuV) + Correction Factor(dB/m)
2. Correction Factor(dB/m) = Antenna Factor (dB/m) + Cable Factor (dB) – Pre-Amplifier Factor (dB)
3. The other emission levels were very low against the limit.
4. Margin value = Emission level – Limit value

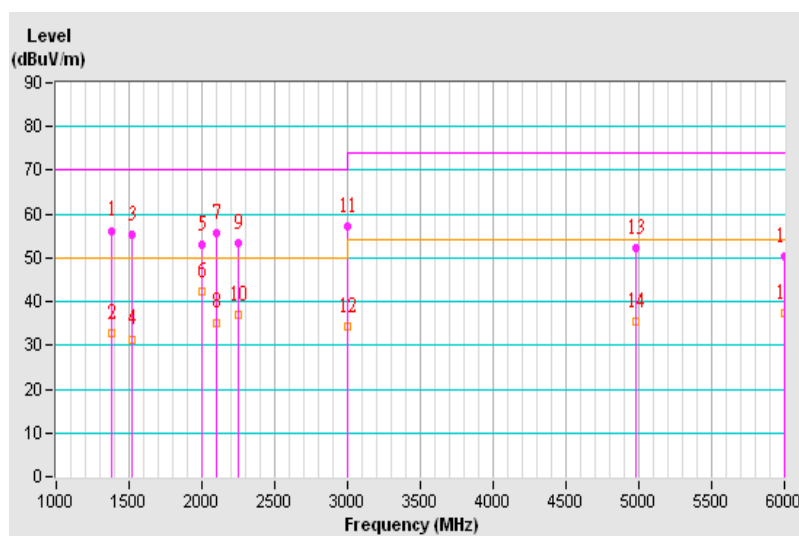

8 General Immunity Requirements

EN 55024:2010, Immunity requirements				
Clause	Reference standard	Table	Test specification	Performance Criterion
4.2.1	EN/IEC 61000-4-2 ESD	1.3	Enclosure port: ±8kV Air discharge, ±4kV Contact discharge	B
4.2.3.2	EN/IEC 61000-4-3 RS	1.2	Enclosure port: 80-1000 MHz, 3V/m, 80% AM (1kHz)	A
4.2.4	EN/IEC 61000-4-8 PFMF	1.1	Enclosure port: 50 or 60 Hz, 1A/m	A

8.1 Performance Criteria

General Performance Criteria

Performance criterion A

The equipment shall continue to operate as intended without operator intervention. No degradation of performance or loss of function is allowed below a performance level specified by the manufacturer when the equipment is used as intended. The performance level may be replaced by a permissible loss of performance. If the minimum performance level or the permissible performance loss is not specified by the manufacturer, then either of these may be derived from the product description and documentation, and by what the user may reasonably expect from the equipment if used as intended.

Performance criterion B

After the test, the equipment shall continue to operate as intended without operator intervention. No degradation of performance or loss of function is allowed, after the application of the phenomena below a performance level specified by the manufacturer, when the equipment is used as intended. The performance level may be replaced by a permissible loss of performance. During the test, degradation of performance is allowed. However, no change of operating state or stored data is allowed to persist after the test. If the minimum performance level (or the permissible performance loss) is not specified by the manufacturer, then either of these may be derived from the product description and documentation, and by what the user may reasonably expect from the equipment if used as intended.

Performance criterion C

Loss of function is allowed, provided the function is self-recoverable, or can be restored by the operation of the controls by the user in accordance with the manufacturer's instructions. Functions, and/or information stored in non-volatile memory, or protected by a battery backup, shall not be lost.

Product Specific Performance Criteria

The particular performance criteria which are specified in the normative annexes of EN 55024 take precedence over the corresponding parts of the general performance criteria.

Where particular performance criteria for specific functions are not given, then the general performance criteria shall apply.

9 Electrostatic Discharge Immunity Test (ESD)

9.1 Test Specification

Basic Standard:	EN/IEC 61000-4-2
Discharge Impedance:	330 ohm / 150 pF
Discharge Voltage:	Air Discharge: $\pm 2, \pm 4, \pm 8$ kV (Direct) Contact Discharge: $\pm 2, \pm 4$ kV (Direct & Indirect)
Number of Discharge:	Air – Direct: 10 discharges per location (each polarity) Contact – Direct & Indirect: 25 discharges per location (each polarity) and min. 200 times in total
Discharge Mode:	Single Discharge
Discharge Period:	1-second minimum

9.2 Test Instruments

Description & Manufacturer	Model No.	Serial No.	Cal. Date	Cal. Due
KeyTek, ESD Simulator	MZ-15/EC	0401299	Oct. 16, 2015	Oct. 15, 2016

- Notes:
1. The calibration interval of the above test instruments is 12 months and the calibrations are traceable to NML/ROC and NIST/USA.
 2. The test was performed in ESD Room No. 3.
 3. Tested Date: Dec. 10, 2015.

9.3 Test Arrangement

The discharges shall be applied in two ways:

- a. Contact discharges to the conductive surfaces and coupling planes:

The EUT shall be exposed to at least 200 discharges, 100 each at negative and positive polarity, at a minimum of four test points. One of the test points shall be subjected to at least 50 indirect discharges to the center of the front edge of the horizontal coupling plane. The remaining three test points shall each receive at least 50 direct contact discharges. If no direct contact test points are available, then at least 200 indirect discharges shall be applied in the indirect mode. Test shall be performed at a maximum repetition rate of one discharge per second.

- b. Air discharges at slots and apertures and insulating surfaces:

On those parts of the EUT where it is not possible to perform contact discharge testing, the equipment should be investigated to identify user accessible points where breakdown may occur. Such points are tested using the air discharge method. This investigation should be restricted to those area normally handled by the user. A minimum of 10 single air discharges shall be applied to the selected test point for each such area.

The basic test procedure was in accordance with EN/IEC 61000-4-2:

- a. Electrostatic discharges were applied only to those points and surfaces of the EUT that are accessible to users during normal operation.
- b. The test was performed with at least ten single discharges on the pre-selected points in the most sensitive polarity.
- c. The time interval between two successive single discharges was at least 1 second.
- d. The ESD generator was held perpendicularly to the surface to which the discharge was applied and the return cable was at least 0.2 meters from the EUT.
- e. Contact discharges were applied to the non-insulating coating, with the pointed tip of the generator penetrating the coating and contacting the conducting substrate.
- f. Air discharges were applied with the round discharge tip of the discharge electrode approaching the EUT as fast as possible (without causing mechanical damage) to touch the EUT. After each discharge, the ESD generator was removed from the EUT and re-triggered for a new single discharge. The test was repeated until all discharges were complete.
- g. At least ten single discharges (in the most sensitive polarity) were applied to the **Horizontal Coupling Plane** at points on each side of the EUT. The ESD generator was positioned at a distance of 0.1 meters from the EUT with the discharge electrode touching the **HCP**.
- h. At least ten single discharges (in the most sensitive polarity) were applied to the center of one vertical edge of the **Vertical Coupling Plane** in sufficiently different positions that the four faces of the EUT were completely illuminated. The **VCP** (dimensions 0.5m x 0.5m) was placed vertically to and 0.1 meters from the EUT.

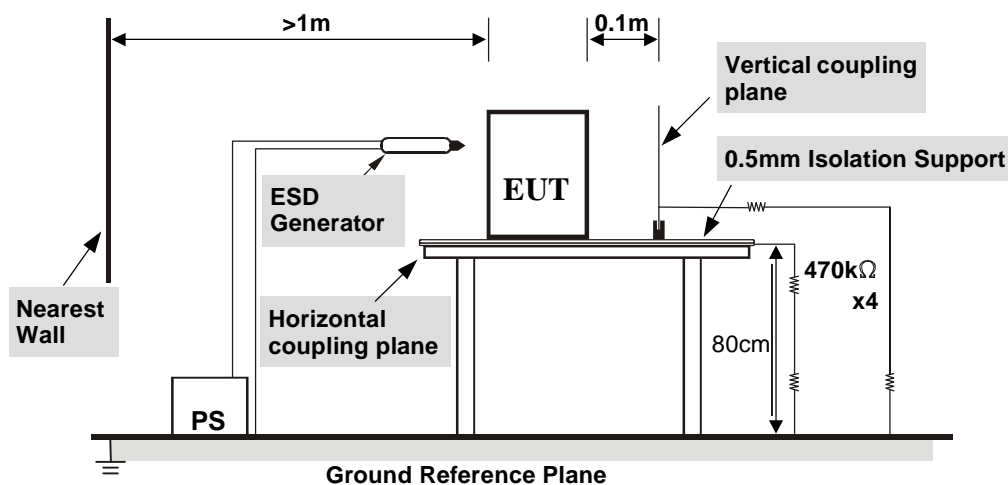

TABLE-TOP EQUIPMENT

The configuration consisted of a wooden table 0.8 meters high standing on the **Ground Reference Plane**. The **GRP** consisted of a sheet of aluminum at least 0.25mm thick, and 2.5 meters square connected to the protective grounding system. A **Horizontal Coupling Plane** (1.6m x 0.8m) was placed on the table and attached to the **GRP** by means of a cable with 940kΩ total impedance. The equipment under test, was installed in a representative system as described in section 7 of EN/IEC 61000-4-2, and its cables were placed on the **HCP** and isolated by an insulating support of 0.5mm thickness. A distance of 1-meter minimum was provided between the EUT and the walls of the laboratory and any other metallic structure.

For the actual test configuration, please refer to the related item – Photographs of the Test Configuration.

9.4 Test Results

Test mode	With system	Input Power < From system >	230 Vac, 50 Hz
Environmental conditions	25°C, 46% RH 1012mbar	Tested by	Todd Chang

Test Results of Direct Application					
Discharge Level (kV)	Polarity (+/-)	Test Point	Contact Discharge	Air Discharge	Performance Criterion
2	+/-	1	Note 1	NA	A
4	+/-	1	Note 2	NA	B
2, 4, 8	+/-	2	NA	Note 1	A

Description of test points of direct application: Please refer to following page for representative mark only.

Test Results of Indirect Application					
Discharge Level (kV)	Polarity (+/-)	Test Point	Horizontal Coupling Plane	Vertical Coupling Plane	Performance Criterion
2, 4	+/-	Four Sides	Note 1	Note 1	A

Description of test points of indirect application:

1. Front side 2. Rear side 3. Right side 4. Left side

Note: 1. The EUT function was correct during the test.
2. The WinEMC R/W delay 1~ 2 seconds during the test, but could self-recover after the test.

Description of Test Points

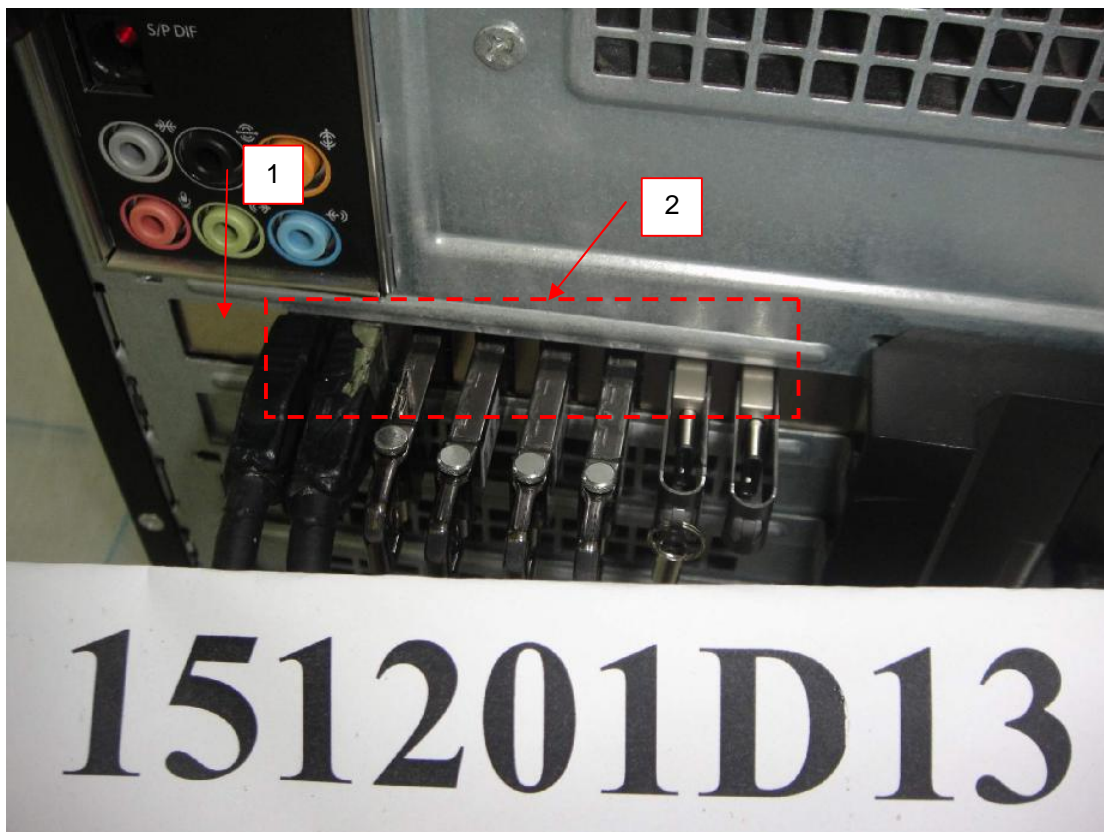

10 Radiated, Radio-frequency, Electromagnetic Field Immunity Test (RS)

10.1 Test Specification

Basic Standard:	EN/IEC 61000-4-3
Frequency Range:	80 MHz - 1000 MHz
Field Strength:	3 V/m
Modulation:	1kHz Sine Wave, 80%, AM Modulation
Frequency Step:	1 % of preceding frequency value
Polarity of Antenna:	Horizontal and Vertical
Antenna Height:	1.5m
Dwell Time:	3 seconds

10.2 Test Instruments

Description & Manufacturer	Model No.	Serial No.	Cal. Date	Cal. Due
Agilent Signal Generator	E8257D	MY48050465	Jul. 21, 2015	Jul. 20, 2016
PRANA RF Amplifier	AP32DP280	0811-894	NA	NA
TESEQ RF Amplifier	CBA1G-150	T44220	NA	NA
AR RF Amplifier	35S4G8AM4	0326094	NA	NA
AR RF Amplifier	100S1G4M3	0329249	NA	NA
AR Controller	SC1000M3	305910	NA	NA
Radisense Electric Field Sensor	CTR1002A	08D00057SNO-07	Nov. 25, 2015	Nov. 24, 2016
BOONTON RF Voltage Meter	4232A	10180	Jun. 01, 2015	May 31, 2016
BOONTON Power Sensor	51011-EMC	34152	Jun. 01, 2015	May 31, 2016
BOONTON Power Sensor	51011-EMC	34153	Jun. 01, 2015	May 31, 2016
AR Log-Periodic Antenna	AT6080	0329465	NA	NA
EMCO BiconiLog Antenna	3141	1001	NA	NA
AR High Gain Antenna	AT4002A	306533	NA	NA
AR High Gain Horn Antenna	AT4010	0329800	NA	NA
CHANCE MOST Full Anechoic Chamber (9x5x3m)	Chance Most	RS-002	Feb. 05, 2015	Feb. 04, 2016
Software	RS_V7.6	NA	NA	NA

- Notes:
1. The calibration interval of the above test instruments is 12 months and the calibrations are traceable to NML/ROC and NIST/USA.
 2. The test was performed in RS Room No.2.
 3. Tested Date: Dec. 9, 2015.

10.3 Test Arrangement

The test procedure was in accordance with EN/IEC 61000-4-3.

- a. The testing was performed in a modified semi-anechoic chamber.
- b. The frequency range is swept from 80 MHz to 1000 MHz, with the signal 80% amplitude modulated with a 1kHz sine wave.
- c. The field strength level was 3 V/m.
- d. The test was performed with the EUT exposed to both vertically and horizontally polarized fields on each of the four sides.

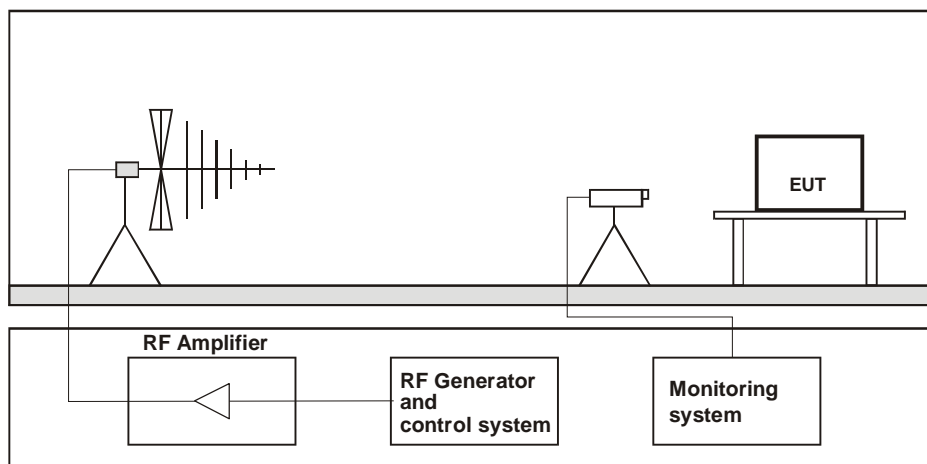

Table-top Equipment

The EUT installed in a representative system as described in section 7 of EN/IEC 61000-4-3 was placed on a non-conductive table 0.8 meters in height. The system under test was connected to the power and signal wire according to relevant installation instructions.

For the actual test configuration, please refer to the related item – Photographs of the Test Configuration.

10.4 Test Results

Test mode	With system	Input Power < From system >	230 Vac, 50 Hz
Environmental conditions	21 °C, 65% RH	Tested by	Thomas Cheng

Frequency (MHz)	Polarity	Azimuth(°)	Applied Field Strength		Observation	Performance Criterion
			(V/m)	Modulation		
80 -1000	V&H	0	3	80% AM (1kHz)	Note	A
80 -1000	V&H	90	3	80% AM (1kHz)	Note	A
80 -1000	V&H	180	3	80% AM (1kHz)	Note	A
80 -1000	V&H	270	3	80% AM (1kHz)	Note	A

Note: The EUT function was correct during the test.

11 Power Frequency Magnetic Field Immunity Test

11.1 Test Specification

Basic Standard:	EN/IEC 61000-4-8
Frequency Range:	50Hz
Field Strength:	1 A/m
Observation Time:	1 minute
Inductance Coil:	Rectangular type, 1 m x 1 m

11.2 Test Instruments

Description & Manufacturer	Model No.	Serial No.	Cal. Date	Cal. Due
HAEFELY Magnetic Field Tester	MAG 100	083794-06	NA	NA
COMBINOVA Magnetic Field Meter	MFM10	224	Apr. 24, 2015	Apr. 23, 2016

Notes: 1. The calibration interval of the above test instruments is 12 months and the calibrations are traceable to NML/ROC and NIST/USA.

2. The test was performed in EMS Room No. 1

3. Tested Date: Dec. 9, 2015.

11.3 Test Arrangement

- The equipment is configured and connected to satisfy its functional requirements.
- The power supply, input and output circuits shall be connected to the sources of power supply, control and signal.
- The cables supplied or recommended by the equipment manufacturer shall be used. 1 meter of all cables used shall be exposed to the magnetic field.

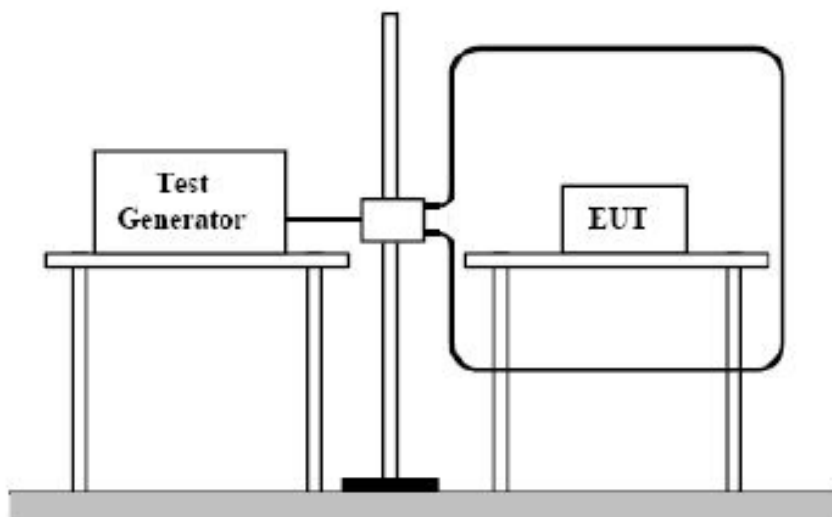

TABLETOP EQUIPMENT

The equipment shall be subjected to the test magnetic field by using the induction coil of standard dimension (1 m x 1 m). The induction coil shall then be rotated by 90 degrees in order to expose the EUT to the test field with different orientations.

For the actual test configuration, please refer to the related item – Photographs of the Test Configuration.

11.4 Test Results

Test mode	With system	Input Power < From system >	230 Vac, 50 Hz
Environmental conditions	25 °C, 70% RH	Tested by	Chiming Li

Application	Frequency (Hz)	Field Strength (A/m)	Observation	Performance Criterion
X - Axis	50	1	Note	A
Y - Axis	50	1	Note	A
Z - Axis	50	1	Note	A

Note: The EUT function was correct during the test.

12 Pictures of Test Arrangements

12.1 Conducted Disturbance at Mains Ports



12.2 Radiated Disturbance up to 1 GHz



12.3 Radiated Disturbance above 1 GHz



12.4 Electrostatic Discharge Immunity Test (ESD)

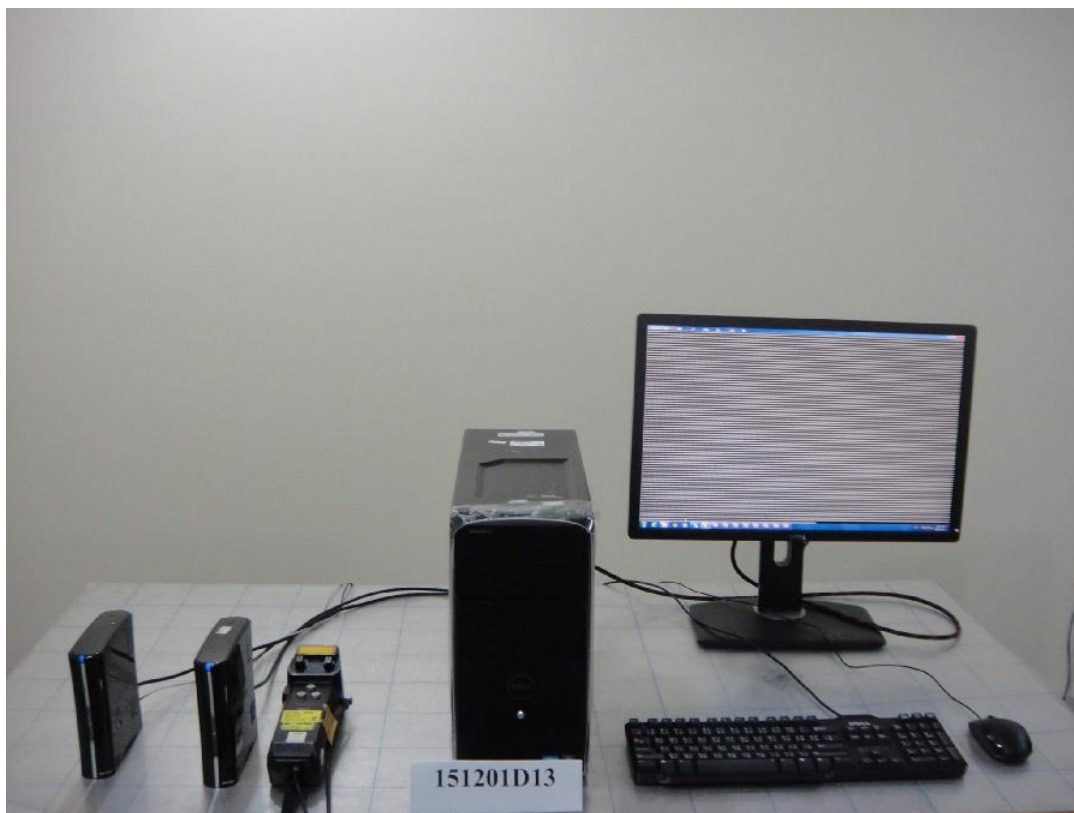

12.5 Radio-frequency, Electromagnetic Field Immunity Test (RS)

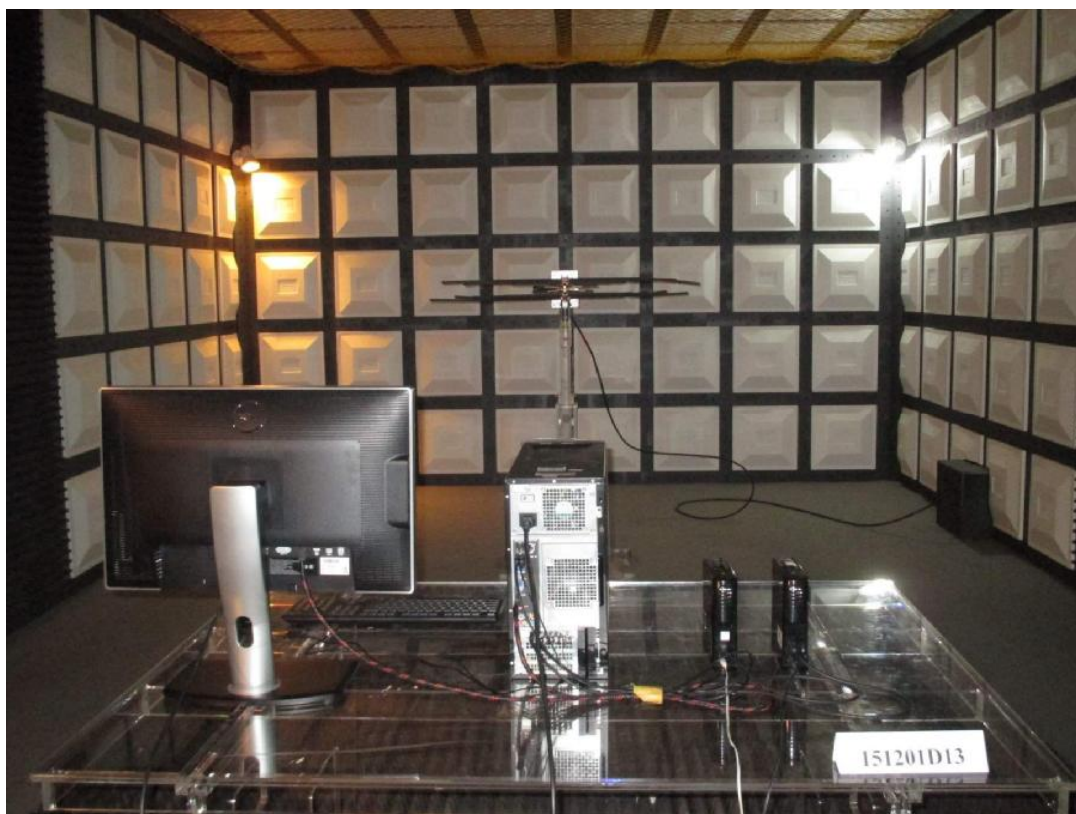

12.6 Power Frequency Magnetic Field Immunity Test (PFMF)



Appendix – Information on the Testing Laboratories

We, Bureau Veritas Consumer Products Services (H.K.) Ltd., Taoyuan Branch, were founded in 1988 to provide our best service in EMC, Radio, Telecom and Safety consultation. Our laboratories are accredited and approved according to ISO/IEC 17025.

If you have any comments, please feel free to contact us at the following:

Linko EMC/RF Lab

Tel: 886-2-26052180

Fax: 886-2-26051924

Hsin Chu EMC/RF/Telecom Lab

Tel: 886-3-6668565

Fax: 886-3-6668323

Hwa Ya EMC/RF/Safety Lab

Tel: 886-3-3183232

Fax: 886-3-3270892

Email: service.adt@tw.bureauVeritas.com

Web Site: www.bureauVeritas-adt.com

The address and road map of all our labs can be found in our web site also.

--- END ---